

***TB 9-6625-970-50**

DEPARTMENT OF THE ARMY TECHNICAL BULLETIN

CALIBRATION PROCEDURE FOR TIME BASE PLUG-IN PL-1311U AND TEKTRONIX TYPES 2B67 AND 67

Headquarters, Department of the Army, Washington, D. C.
29 August 1975

		Paragraph	Page
SECTION	I.	IDENTIFICATION AND DESCRIPTION	
		Test instrument identification	1 2
		Calibration data card DA Form 2416.....	2 2
		Reporting of errors	3 2
		Calibration description.....	4 2
	II.	EQUIPMENT REQUIREMENTS	
		Equipment required	5 3
		Accessories required.....	6 3
	III.	PRELIMINARY OPERATIONS	
		Preliminary instructions.....	7 4
		Equipment setup	8 4
	IV.	CALIBRATION PROCESS	
		Triggering sensitivity.....	9 4
		Sweep timing.....	10 5
		Sweep length and MAG. REGIS	11 7
		Final procedure	12 8

*This bulletin supersedes TB 9-6625-970-50, 10 December 1970.

CHANGE 1

This change was not available from the proponent or the Publication Distribution Center at the time of the CD release. Please refer to your paper or microfiche copy as appropriate.

NOT DIGITIZED

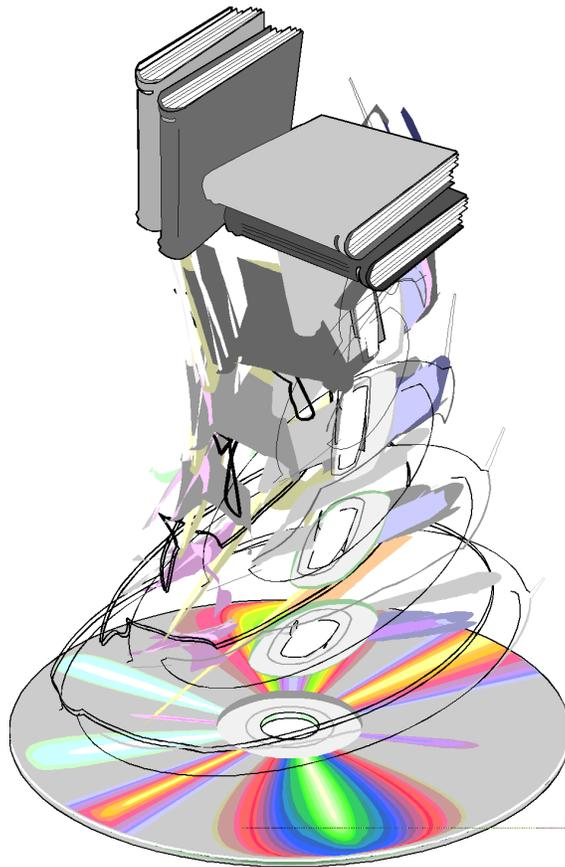

**SECTION I
IDENTIFICATION AND DESCRIPTION**

1. Test Instrument Identification. This bulletin provides instructions for the calibration of Time Base Plug-In PL1311U and Tektronix Types 2B67 and 67. The manufacturer's instruction manual was used as the prime data source in compiling these instructions. The time base plug-in will be referred to as the "TI" (test instrument) throughout this bulletin.

a. Model Variations. None.

b. Time and Technique. The time required for this calibration is approximately 2 hours, using the dc and low frequency technique.

2. Calibration Data Card, DA Form 2416

a. Forms, records, and reports required for calibration personnel at all levels are prescribed by TM 38-750. DA Form 2416 must be annotated in accordance with TM 38-750 for each calibration performed.

b. Adjustments to be reported on DA Form 2416 are designated (R) at the end of the sentence in which they appear. When adjustments are in tables, the (R) will follow the designated adjustment. Report only those adjustments made and designated with (R).

3. Reporting of Errors. The reporting of errors, omissions, and recommendations for improving this publication by the individual user is encouraged. Reports should be submitted on DA Form 2028, Recommended Changes to Publications, and forwarded direct to Commander, U.S. Army Missile Command, ATTN: AMSMI-MFPA, Redstone Arsenal, AL 35809.

4. Calibration Description. TI parameters and performance specifications which pertain to this calibration are listed in table 1.

Table 1. Calibration Description

Test Instrument Parameters	Performance Specifications
Triggering: Internal External	Requires producing 2 minor div of deflection. Requires signal from 0.5 V at dc to 2.0 V at 2 MHz. Sweep will trigger on larger signals, but LEVEL control limit is +10 V.
Sweep rates: Range	Calibrated: 1μsec to 5 sec per division in 21 steps. Uncalibrated: Continuously variable to about 3 times TIME/DIV switch setting.
Accuracy	±3% of TIME/DIV switch setting and +5% of magnified rates.

Table 1. Calibration Description - Continued

Test instrument parameters	Performance specifications
Single sweep ¹	Allows sweep to operate only after manual reset for either triggered or free-running operation.

¹This specification is for information only and is not necessarily verified in this bulletin.

SECTION II EQUIPMENT REQUIREMENTS

5. Equipment Required. Table 2 identifies the specific equipment used in this calibration procedure. This equipment is issued with secondary transfer calibration standards set and is to be used in performing this procedure. Alternate items may be used by the calibrating activity when the equipment listed in table 2 is not available. The items selected must be verified to perform satisfactorily prior to use and must bear evidence of current calibration. The equipment must meet or exceed the minimum use specifications listed in table 2. The accuracies listed in table 2 provide a four-to-one accuracy ratio between the standard and TI. Where the four-to-one ratio cannot be met, the actual accuracy of the equipment selected is shown in parenthesis.

6. Accessories Required. The accessories listed in table 3 are issued with secondary transfer calibration standards set and are to be used in this calibration procedure. When necessary, these items may be substituted by equivalent items unless specifically prohibited.

Table 2. Minimum Specifications of Equipment Required

Item	Common Name	Minimum Use Specifications.	Manufacturer, Model, and Part Number
A1	AC/DC VOLTMETER	Range: 0 to 50 V dc Accuracy: ±0.75%	Dana, Model 5703-S-2127 (7912606)
A2	OSCILLOSCOPE	Must be compatible with TI	Tektronix, Type RM561A (7912606) with plug-in 3A6 (7911441-1)
A3	TIME-MARK GENERATOR.	Range: 1µsec to 5 sec Accuracy: ±0.75%	Tektronix, Type 184A MOD 146B (7912042-2)

Table 3. Accessories Required

Item	Common Name	Description and Part Number
B1	ADAPTER	BNC plug to double banana jack (7909401)
B2	CABLE	48-in., RG-58A/U; BNC plug terminations (10519140)
B3	EXTENSION	Tektronix, Type 012-0066-00 (7911755)
B4	LEAD	4-in., No. 18 AWG; single banana plug terminations (7907491)

**SECTION III
PRELIMINARY OPERATIONS**

7. Preliminary Instructions

a. The instructions outlined in this section are preparatory to the calibration process. Personnel should become familiar with the entire bulletin before beginning the calibration.

b. Items of equipment used in this procedure are referenced within the text by common name and item identification number as listed in tables 2 and 3. For the identification of equipment referenced by item numbers prefixed with A, see table 2, and for prefix B, see table 3.

WARNING

HIGH VOLTAGE is used during the performance of this calibration. DEATH ON CONTACT may result if personnel fail to observe safety precautions.

8. Equipment Setup

a. Connect TI to oscilloscope (A2) horizontal compartment, using extension (B3).

b. Energize equipment and allow 20 minutes for warmup.

**SECTION IV
CALIBRATION PROCESS**

NOTE

Unless otherwise specified, verify the results of each test and take corrective action whenever the test requirement is not met before continuing with the calibration.

9. Triggering Sensitivity

a. Performance Check

(1) Position TI controls as listed in (a) through (g) below:

- (a) TIME/DIV. switch to 2 mSEC.
- (b) VARIABLE control to CALIBRATED and pushed in (5X MAG. off).
- (c) LEVEL control to 0 (zero).
- (d) SLOPE switch to + (positive).

- (e) COUPLING switch to AC SLOW.
- (f) SOURCE switch to INT.
- (g) MODE switch to NORM.

(2) Connect oscilloscope (A2) CAL. OUT jack to dual trace plug-in (part of A2) CH 1 input, using cable (B2).

(3) Adjust dual trace plug-in CH 1 controls and oscilloscope CALIBRATOR for 4 millimeters (two minor divisions) of vertical amplitude on crt.

(4) Adjust TI LEVEL control for stable display and set S LOPE switch to - (negative). If sweep does not remain stable, perform *b* below.

b. Adjustments.

(1) Remove cable (B2) and turn TI LEVEL control to AUTO.

(2) Connect adapter (B1) to CH 1 input and short the banana jacks, using lead (B4).

(3) Deenergize TI and connect ac/dc voltmeter (A1) between chassis ground and junction of R112 and R113 (5th notch from right on ceramic strip located immediately above V24 when TI is viewed from left side).

(4) Energize TI and turn STABILITY adjustment (front panel) fully counterclockwise.

(5) Turn TI STABILITY adjustment slowly clockwise until stable trace is first observed on oscilloscope crt. Record ac/dc voltmeter indication.

(6) Continue STABILITY adjustment clockwise until sweep brightens and record ac/dc voltmeter indication.

(7) Compute average of indications recorded in (5) and (6) above. Adjust STABILITY adjustment for computed average as indicated on ac/dc voltmeter.

10. Sweep Timing

a. Performance Check

(1) Position TI controls as listed in (a) through (e) below:

- (a) TIME/DIV. switch to 5 mSEC.
- (b) LEVEL control to 0 (zero).

TB 9-6625-970-50

- (c) SLOPE switch to + (positive).
- (d) COUPLING switch to AC FAST.
- (e) 5X MAG. switch to on (pulled out) position.

(2) Connect time-mark generator (A3) to dual trace plug-in (part of A2) CH 1 input, using cable (B2).

(3) Set time-mark generator to 1 mS markers.

(4) Adjust plug-in (part of A2) controls for 4 major divisions of amplitude on oscilloscope (A2) crt.

(5) Readjust TI LEVEL control as required for stable display on oscilloscope crt.

(6) Adjust TI POSITION control to aline second marker with second vertical graticule line. If 10th marker is not within ± 2.5 minor divisions of 10th vertical graticule line, perform **b** below.

(7) Set TI 5X MAG. switch to off (pushed in) position.

(8) Repeat technique of (3) through (6) above, using switch positions and values listed in table 4. At each setting, if 10th marker (1/div) or 18th marker (2/div) is not within ± 1.5 minor divisions of 10th vertical graticule line, perform corresponding adjustments listed in table 4 and shown in figure 1.

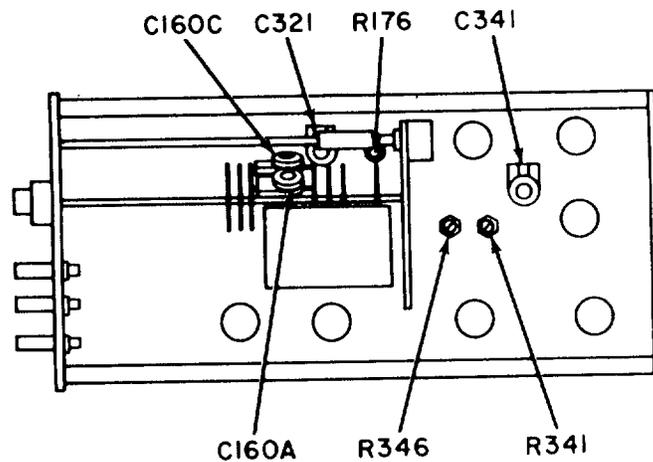

Figure 1. Adjustment locations - right side view.

Table 4. Sweep Timing

Time-mark generator switch settings	Test instrument TIME/DIV switch settings	Oscilloscope indications (markers per div)	Adjustments (fig. 1)
5 mS	5 mSEC	1	R341 (R)
1 μ S	1 μ SEC	1	C341 ¹ (R)
1 μ S	2 μ SEC	2	---
1 μ S	5 μ SEC ²	1	C160A (R)
5 μ S	5 μ SEC	1	---
10 μ S	10 μ SEC	1	---
1 μ S	10 μ SEC ²	2	C321 ³ (R)
10 μ S	20 μ SEC	2	---
10 μ S	50 μ SEC ²	1	C160C ⁴ (R)
50 μ S	50 μ SEC	1	---
.1 mS	.1 mSEC	1	---
.1 mS	.2 mSEC	2	---
.5 mS	.5 mSEC	1	---
1 mS	1 mSEC	1	---
1 mS	2 mSEC	2	---
5 mS	5 mSEC	1	---
10 mS	10 mSEC	1	---
10 mS	20 mSEC	2	---
50 mS	50 mSEC	1	---
.1 S	.1 SEC	1	---
.1 S	.2 SEC	2	---
.5 S	.5 SEC	1	---
1 S	1 SEC	1	---
1 S	2 SEC	2	---
5 S	5 SEC	1	---

¹Position display horizontally to aline first time marker with graticule centerline.

²Pull out 5X MAG. switch for this check and push in after completion; tolerance of ± 2.5 minor divisions is allowed.

³Position display so that first 21 markers at left end trace are displayed.

⁴Position display so that last 11 time markers at right end of trace are displayed.

b. Adjustments. Adjust TI CALIBRATION adjustment (front panel) for 1 marker per graticule division on oscilloscope crt.

11. Sweep Length and MAG. REGIS

a. Performance Check

- (1) Turn TI TIME/DIV switch to 10 μ SEC.
- (2) Set time-mark generator to 1 μ S markers.

TB 9-6625-970-50

(3) Adjust TI POSITION control to aline start of sweep with first vertical graticule line on oscilloscope (A2) crt. If crt does not display 5 markers beyond 11th graticule line, perform **b**(1) below.

(4) Pull out TI 5X MAG. switch.

(5) Adjust TI POSITION control to aline first marker with center vertical graticule line.

(6) Push in TI 5X MAG. switch. If first marker does not remain within ± 1.5 minor divisions of center vertical graticule line, perform **b**(2) and (3) below.

b. Adjustments

(1) Adjust R176 (fig. 1) until 5 markers are displayed beyond 11th graticule line.

(2) Adjust R346 (fig. 1) until first marker is alined with center graticule line (R).

(3) Pull out 5X MAG. switch and, if required, repeat **a**(5) and (6) above.

12. Final Procedure

a. Deenergize and disconnect all equipment.

b. In accordance with TM 38-750, annotate and affix DA Label 80 (U.S. Army Calibration System). When the TI cannot be adjusted within tolerance, annotate and affix DA Form 2417 (Unserviceable or Limited Use) tag.

TB 9-6625-970-50

By Order of the Secretary of the Army:

FRED C. WEYAND
General, United States Army
Chief of Staff

Official:

VERNE L. BOWERS
Major General, United States Army
The Adjutant General

Distribution:

To be distributed in accordance with DA Form 12-34, Section II, (qty rqr block No. 75) requirements for Calibration Procedures Publications.

*U.S. GOVERNMENT PRINTING OFFICE: 1975-641219/5012

PIN NO: 011221-000

RECOMMENDED CHANGES TO EQUIPMENT TECHNICAL PUBLICATIONS



THEN...JOT DOWN THE
DOPE ABOUT IT ON THIS FORM.
CAREFULLY TEAR IT OUT, FOLD IT
AND DROP IT IN THE MAIL.

SOMETHING WRONG WITH PUBLICATION

FROM: (PRINT YOUR UNIT'S COMPLETE ADDRESS)

DATE SENT

PUBLICATION NUMBER

PUBLICATION DATE

PUBLICATION TITLE

BE EXACT PIN-POINT WHERE IT IS

PAGE
NO.

PARA-
GRAPH

FIGURE
NO.

TABLE
NO.

IN THIS SPACE, TELL WHAT IS WRONG
AND WHAT SHOULD BE DONE ABOUT IT.

TEAR ALONG PERFORATED LINE

PRINTED NAME, GRADE OR TITLE AND TELEPHONE NUMBER

SIGN HERE

